

**Свойства**

передача данных по одному волокну

до 20км на 9/125 мкм одномодовом оптическом кабеле

цифровая диагностика (DDMI)

до 155Mbps

SC коннектор

**Применение**

Fast Ethernet

STM-1 / OC-3

**● Максимальные параметры**

Parameter	Symbol	Min.	Typical	Max.	Unit
Storage Temperature	T <sub>s</sub>	-40		+85	°C
Supply Voltage	V <sub>ccT, R</sub>	-0.5		4	V
Relative Humidity	RH	0		85	%
Case Operating Temperature	T <sub>op</sub>	-5		+70	°C

**● Рекомендованные параметры**

Parameter	Symbol	Min.	Typical	Max.	Unit
-----------	--------	------	---------	------	------

Case operating Temperature	$T_C$	-5		+70	°C
Supply Voltage	$V_{CC,T,R}$	3.0		3.6	V
Power Supply Rejection		100			mV <sub>P-P</sub>

● **Электрические характеристики**

Parameter	Symbol	Min.	Typical	Max.	Unit	Note
Supply Voltage	$V_{CC}$	3.0	3.30	3.60	V	
Supply Current	$I_{CC}$		160	280	mA	
Inrush Current	$I_{surge}$			$I_{CC}+30$	mA	
Maximum Power	$P_{max}$			1.0	W	
<b>Transmitter Section:</b>						
Input differential impedance	$R_{in}$	90	100	110	$\Omega$	1
Single ended data input swing	$V_{in PP}$	200		1200	mVp-p	
Transmit Disable Voltage	$V_D$	$V_{CC} - 1.3$		$V_{CC}$	V	2
Transmit Enable Voltage	$V_{EN}$	$V_{EE}$		$V_{EE} + 0.8$	V	
Transmit Disable Assert Time	$T_{dessert}$			10	us	
<b>Receiver Section:</b>						
Single ended data output swing	$V_{out,pp}$	300		1000	mv	3
Data output rise time	$t_r$			150	ps	4
Data output fall time	$t_f$			150	ps	4
LOS Fault	$V_{losfault}$	$V_{CC} - 0.5$		$V_{CC\_host}$	V	5
LOS Normal	$V_{los norm}$	$V_{EE}$		$V_{EE} + 0.5$	V	5

Power Supply Rejection	PSR	100			mVpp	6
------------------------	-----	-----	--	--	------	---

Note:

1. AC coupled.
2. Or open circuit.
3. Into 100 ohm differential termination.
4. 20 – 80 %
5. LOS is LVTTTL. Logic 0 indicates normal operation; logic 1 indicates no signal detected.
6. All transceiver specifications are compliant with a power supply sinusoidal modulation of 20 Hz to 1.5MHz up to specified value applied through the power supply filtering network shown on page 23 of the Small Form-factor Pluggable (SFP) Transceiver Multi-Source Agreement (MSA), September 14, 2000.

● **Оптические параметры**

Parameter	Symbol	Min.	Typical	Max.	Unit	Note
<b>Transmitter Section:</b>						
Center Wavelength	$\lambda_c$	1480	1550	1580	nm	1
Spectral Width	$\sigma$			3	nm	
Optical Output Power	$P_{out}$	-15		-8	dBm	2
Optical Rise/Fall Time	$t_r / t_f$			160	ps	3
Extinction Ratio	ER	10			dB	
Eye Mask for Optical Output	Compliant with Eye Mask Defined in IEEE 802.3 standard					
Relative Intensity Noise	RIN			-120	dB/H z	
<b>Receiver Section:</b>						
Optical Input Wavelength	$\lambda_i$	1270	1310	1360	nm	
Optical Input Power	$P_{in}$	-34		-3	dBm	4.5
Receiver Reflectance		12			dB	
Receiver Overload	$P_{ol}$			-3	dBm	4.5

RX Sensitivity	Sen			-34	dBm	4.5
RX_LOS Assert	LOS <sub>A</sub>	-45			dBm	
RX_LOS Deassert	LOS <sub>D</sub>			-35	dBm	
RX_LOS Hysteresis	LOS <sub>H</sub>		2	2.5	dB	
<b>General Specifications</b>						
Data Rate	BR		155		Mb/s	
Bit Error Rate	BER			10 <sup>-12</sup>		
Max. Supported Link Length on 9/125µm SMF@1.25G	LMAX		20		km	6
Total System Budget	LB	19			dB	7

**Note**

1. Also specified to meet curves in FC-PI 13.0 Figures 18 and 19, which allow trade-off between wavelength spectral width.
2. Class 1 Laser Safety per FDA/CDRH and EN (IEC) 60825 regulations.
3. Unfiltered, 20-80%. Complies with IEEE 802.3 (Gig. E), FC 1x and 2x eye masks when filtered.
4. Measured with conformance signals defined in FC-PI 13.0 specifications.
5. Measured with PRBS 2<sup>31-1</sup> at 10<sup>-12</sup> BER
6. Dispersion limited per FC-PI Rev. 13
7. Attenuation of 0.45 dB/km is used for the link length calculations. Distances are indicative only. Please refer to the Optical Specifications in Table IV to calculate a more accurate link budget based on specific conditions in your application.

● Основные блоки модуля

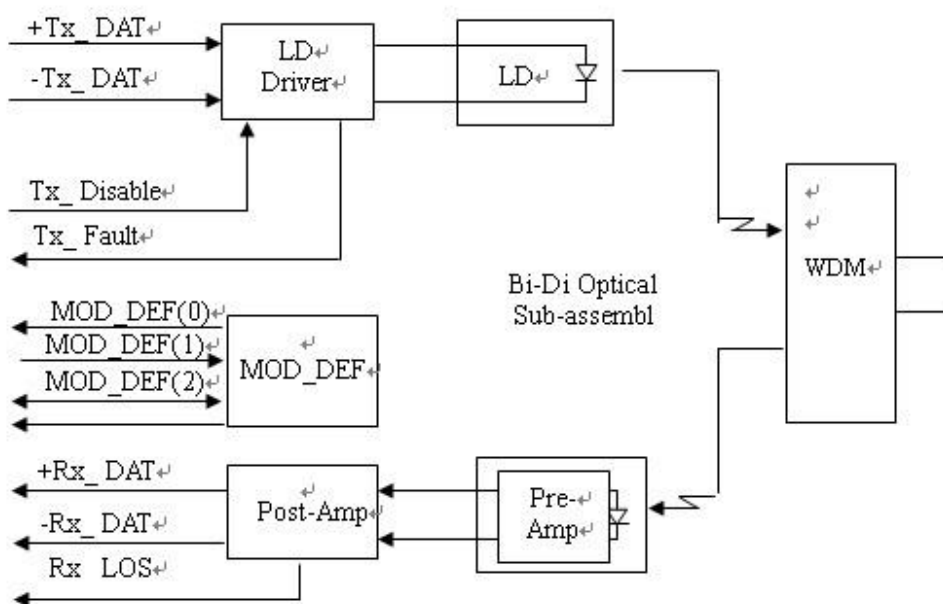

Figure1: Block Diagram

● Назначение контактов

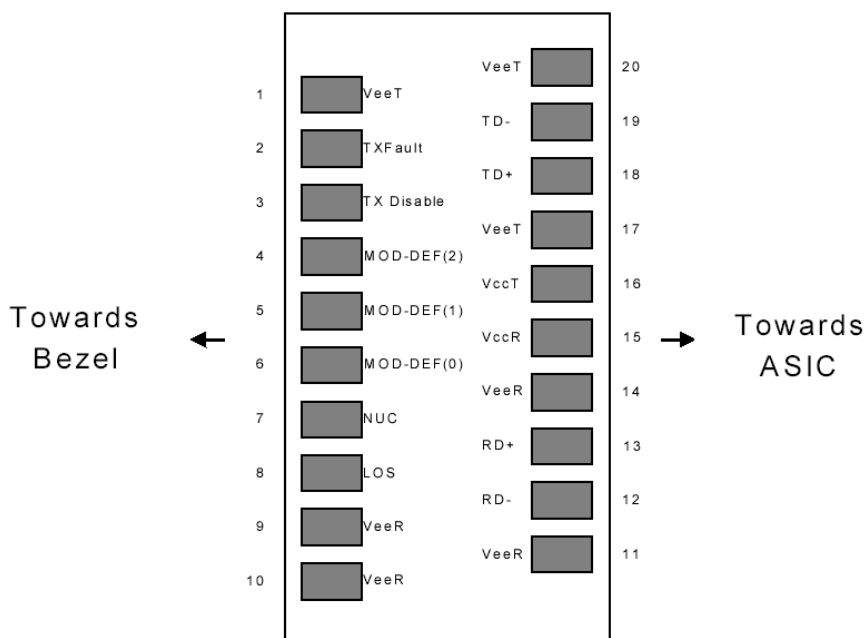

Figure2:Diagram of Host Board Connector Block Pin Numbers and Names

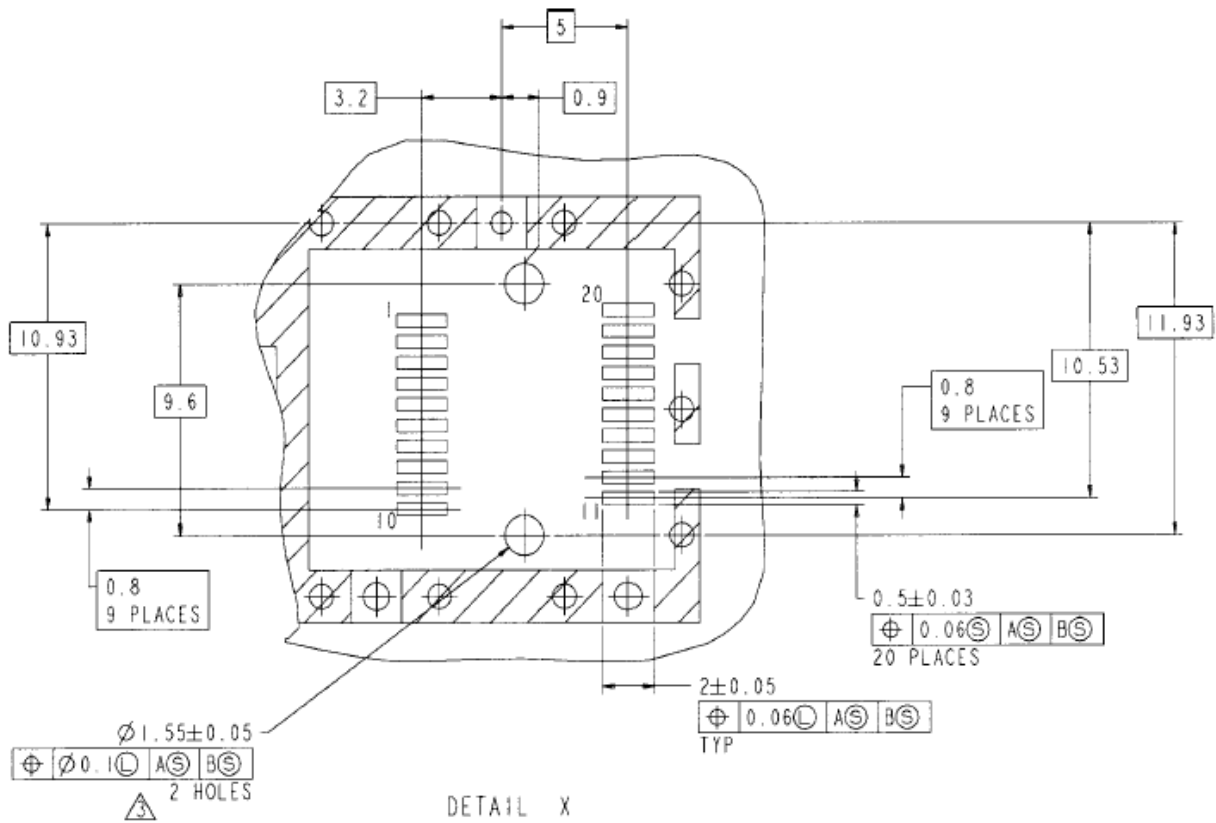

Figure 3. SFP Host Board Mechanical Layout

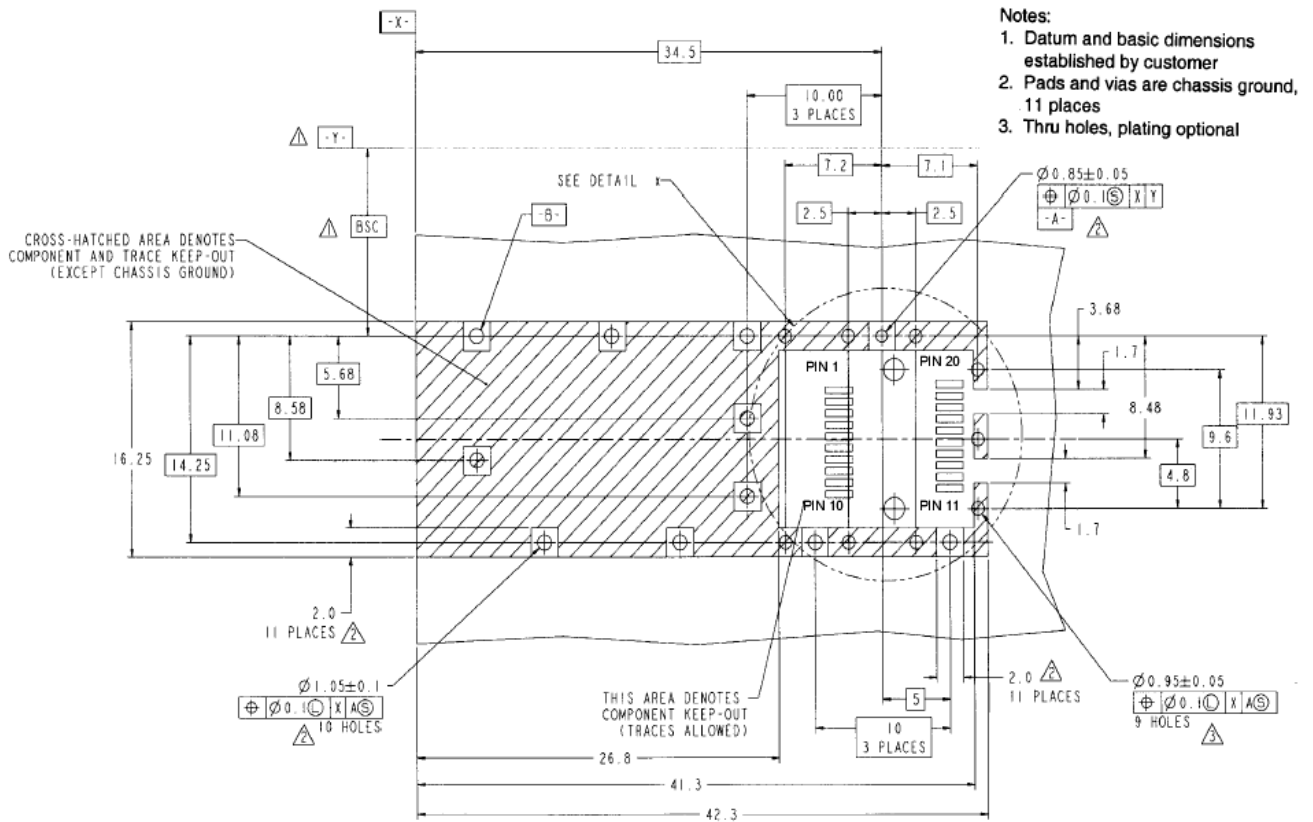

Figure 4. SFP Host Board Mechanical Layout(Cont)

● Описание контактов

Pin No	Name	Function	Plug Seq	Notes
1	VeeT	Transmitter Ground	1	1
2	TX Fault	Transmitter Fault Indication	3	
3	TX Disable	Transmitter Disable	3	2
4	MOD-DEF2	Module Definition	2	3
5	MOD-DEF1	Module Definition 1	3	3
6	MOD-DEF0	Module Definition 0	3	3
7	Rate Select	Not Connected	3	4
8	LOS	Loss of Signal	3	5
9	VeeR	Receiver Ground	1	1

10	VeeR	Receiver Ground	1	1
11	VeeR	Receiver Ground		1
12	RD-	Inv. Received Data Out	3	6
13	RD+	Received Data Out	3	6
14	VeeR	Receiver Ground	3	1
15	VccR	Receiver Power	2	1
16	VccT	Transmitter Power	2	
17	VeeT	Transmitter Ground	1	
18	TD+	Transmit Data In	3	6
19	TD-	Inv. Transmit In	3	6
20	VeeT	Transmitter Ground	1	

**Notes:**

1. Circuit ground is internally isolated from chassis ground.
2. Laser output disabled on TDIS >2.0V or open, enabled on TDIS <0.8V.
3. Should be pulled up with 4.7k - 10 kohms on host board to a voltage between 2.0V and 3.6V. MOD\_DEF(0) pulls line low to indicate module is plugged in.
4. Rate select is not used
5. LOS is open collector output. Should be pulled up with 4.7k – 10 kohms on host board to a voltage between 2.0V and 3.6V. Logic 0 indicates normal operation; logic 1 indicates loss of signal.
6. AC Coupled



● Рекомендованная схема включения

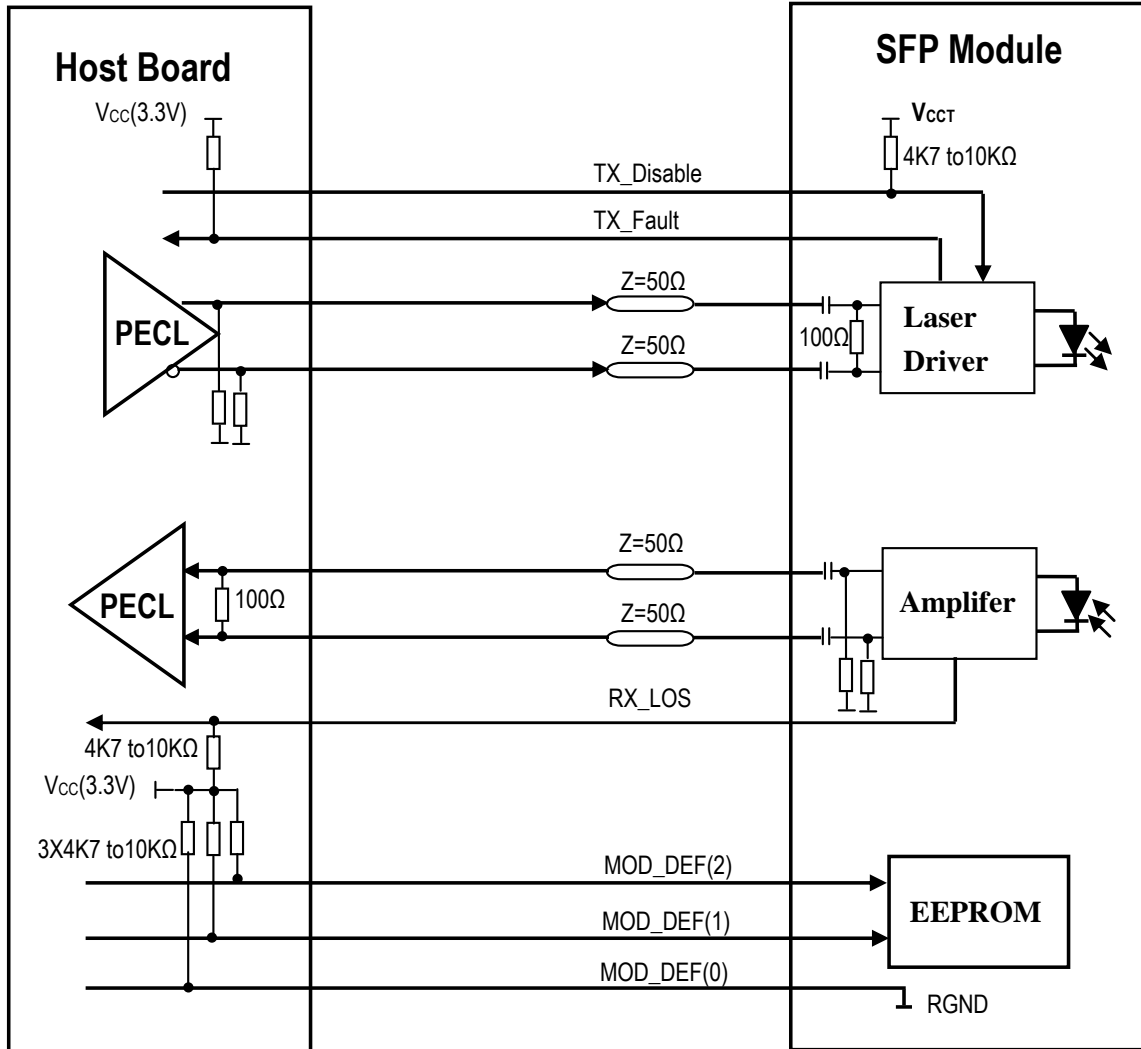

Figure 5. SFP Host Recommended Circuit

● Содержание памяти (EEPROM)

Data Address	Length (Byte)	Name of Length	Description and Contents
Base ID Fields			
0	1	Identifier	Type of Serial transceiver (03h=SFP)

1	1	Reserved	Extended identifier of type serial transceiver (04h)
2	1	Connector	Code of optical connector type (07=LC)
3-10	8	Transceiver	Fast Ethernet
11	1	Encoding	4B5B (02h)
12	1	BR,Nominal	Nominal baud rate, unit of 100Mbps
13	1	Reserved	(0000h)
14	1	Length(9um,km)	Link length supported for 9/125um fiber, units of km
15	1	Length(9um)	Link length supported for 9/125um fiber, units of 100m
16	1	Length(50um)	Link length supported for 50/125um fiber, units of 10m
17	1	Length(62.5um)	Link length supported for 62.5/125um fiber, units of 10m
18	1	Length(Copper)	Link length supported for copper, units of meters
19	1	Reserved	
20-35	16	Vendor Name	SFP vendor name
36	1	Reserved	
37-39	3	Vendor OUI	SFP transceiver vendor OUI ID
40-55	16	Vendor PN	Part Number (ASCII)
56-59	4	Vendor rev	Revision level for part number
60-61	2	Wavelength	Laser wavelength
62	1	Reserved	
63	1	CCID	Least significant byte of sum of data in address 0-62
<b>Extended ID Fields</b>			
64-65	2	Option	Indicates which optical SFP signals are implemented(001Ah = LOS, TX_FAULT, TX_DISABLE all supported)
66	1	BR, max	Upper bit rate margin, units of %

Модуль SFP, 155Mbps, WDM, TX/RX=1550/1310nm, SM, SC, 20km, DDMI

67	1	BR, min	Lower bit rate margin, units of %
68-83	16	Vendor SN	Serial number (ASCII)
84-91	8	Date code	Manufacturing date code
92	1	Diagnostic Type	Diagnostics
93	1	Enhanced Options	Diagnostics
94	1	SFF-8472	Diagnostics
95	1	CCEX	Check code for the extended ID Fields (addresses 64 to 94)
Vendor Specific ID Fields			
96-127	32	Readable	Vendor specific date, read only

● Размеры

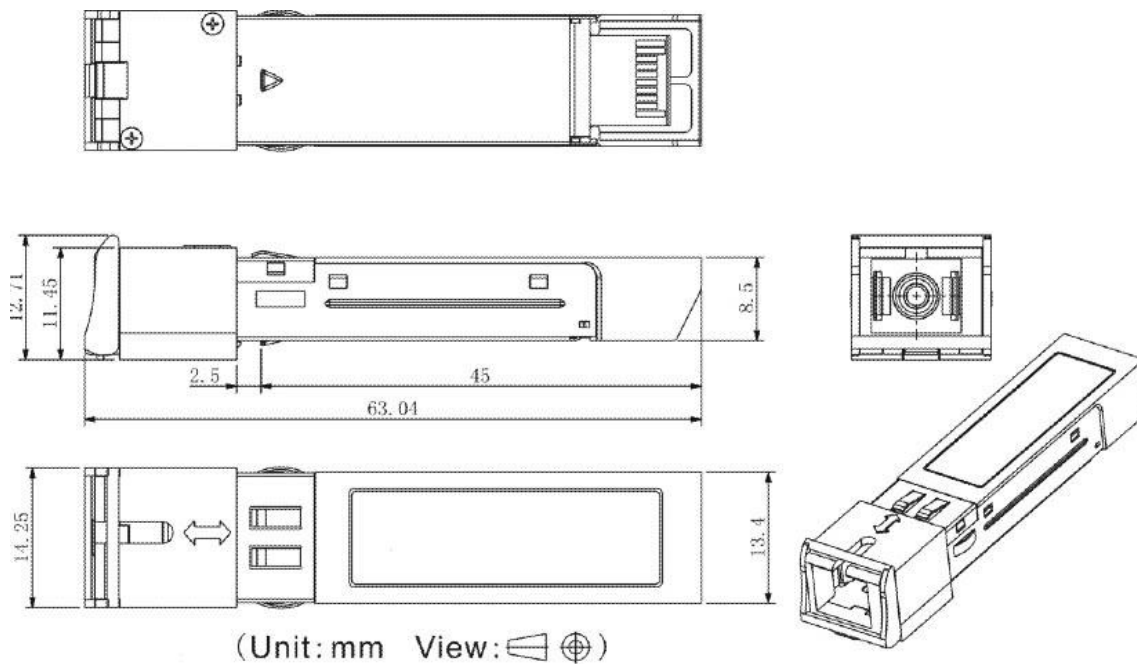

Figure 6. Mechanical Drawing