

Свойства

DWDM EML лазер + APD фотоприемник

100GHz ITU Grid, C Band

до 80км

цифровая диагностика (DDMI)

дуплексный LC коннектор

Применение

10GBase-ZR/ZW

STM-64/16

10G FC

● Модели

OTSFP+-D-80-Cxx , где xx: 100GHZ ITU Grid Wavelength

model	Frequency (THZ)	Central Wavelength(nm)
OTSFP+-D-80-C17	191,70	1563,86
OTSFP+-D-80-C18	191,80	1563,05
OTSFP+-D-80-C19	191,90	1562,23
OTSFP+-D-80-C20	192,00	1561,42
OTSFP+-D-80-C21	192,10	1560,61

OTSFP+-D-80-C22	192,20	1559,79
OTSFP+-D-80-C23	192,30	1558,98
OTSFP+-D-80-C24	192,40	1558,17
OTSFP+-D-80-C25	192,50	1557,36
OTSFP+-D-80-C26	192,60	1556,55
OTSFP+-D-80-C27	192,70	1555,75
OTSFP+-D-80-C28	192,80	1554,94
OTSFP+-D-80-C29	192,90	1554,13
OTSFP+-D-80-C30	193,00	1553,33
OTSFP+-D-80-C31	193,10	1552,52
OTSFP+-D-80-C32	193,20	1551,72
OTSFP+-D-80-C33	193,30	1550,92
OTSFP+-D-80-C34	193,40	1550,12
OTSFP+-D-80-C35	193,50	1549,32
OTSFP+-D-80-C36	193,60	1548,51
OTSFP+-D-80-C37	193,70	1547,72

OTSFP+-D-80-C38	193,80	1546,92
OTSFP+-D-80-C39	193,90	1546,12
OTSFP+-D-80-C40	194,00	1545,32
OTSFP+-D-80-C41	194,10	1544,53
OTSFP+-D-80-C42	194,20	1543,73
OTSFP+-D-80-C43	194,30	1542,94
OTSFP+-D-80-C44	194,40	1542,14
OTSFP+-D-80-C45	194,50	1541,35
OTSFP+-D-80-C46	194,60	1540,56
OTSFP+-D-80-C47	194,70	1539,77
OTSFP+-D-80-C48	194,80	1538,98
OTSFP+-D-80-C49	194,90	1538,19
OTSFP+-D-80-C50	195,00	1537,40
OTSFP+-D-80-C51	195,10	1536,61
OTSFP+-D-80-C52	195,20	1535,82
OTSFP+-D-80-C53	195,30	1535,04

OTSFP+-D-80-C54	195,40	1534,25
OTSFP+-D-80-C55	195,50	1533,47
OTSFP+-D-80-C56	195,60	1532,68
OTSFP+-D-80-C57	195,70	1531,90
OTSFP+-D-80-C58	195,80	1531,12
OTSFP+-D-80-C59	195,90	1530,33
OTSFP+-D-80-C60	196,00	1529,55
OTSFP+-D-80-C61	1528,77	196,10

● Максимальные параметры

Parameter	Symbol	Min.	Typical	Max.	Unit
Storage Temperature	T _S	-40		+85	°C
Case Operating Temperature	T _A	-5		+70	°C
Maximum Supply Voltage	V _{CC}	-0.5		4	V
Relative Humidity	RH	0		85	%

● Электрические характеристики

Parameter	Symbol	Min.	Typical	Max.	Unit	Note
Supply Voltage	V _{CC}	3.135		3.465	V	
Supply Current	I _{CC}			450	mA	

Power Consumption	P			1.5	W	
Transmitter Section:						
Input differential impedance	R_{in}		100		Ω	1
Tx Input Single Ended DC Voltage Tolerance (Ref VeeT)	V	-0.3		4	V	
Differential input voltage swing	$V_{in,pp}$	180		700	mV	2
Transmit Disable Voltage	V_D	2		Vcc	V	3
Transmit Enable Voltage	V_{EN}	Vee		Vee+0.8	V	
Receiver Section:						
Single Ended Output Voltage Tolerance	V	-0.3		4	V	
Rx Output Diff Voltage	V_o	300		850	mV	
Rx Output Rise and Fall Time	T_r/T_f	30			ps	4
LOS Fault	$V_{LOS\ fault}$	2		$V_{CC_{HOST}}$	V	5
LOS Normal	$V_{LOS\ norm}$	Vee		Vee+0.8	V	5

Note:

1. Connected directly to TX data input pins. AC coupling from pins into laser driver IC.
2. Per SFF-8431 Rev 3.0
3. Into 100 ohms differential termination.
4. 20% ~ 80%
5. LOS is an open collector output. Should be pulled up with 4.7k – 10k Ω on the host board. Normal operation is logic 0; loss of signal is logic 1.. Maximum pull-up voltage is 5.5V.

● Оптические параметры

Parameter	Symbol	Min.	Typical	Max.	Unit	Note
Transmitter Section:						
Optical Wavelength-End Of Life	λ	X-100	X	X+100	pm	

Optical Wavelength-Beginning Of Life	λ	X-25	X	X+25	pm	
Average Optical Power	P_{avg}	0		+4	dBm	1
Laser Off Power	P_{off}			-30	dBm	
Extinction Ratio	ER	6			dB	
Transmitter Dispersion Penalty	TDP			3.0	dB	2
Relative Intensity Noise	Rin			-128	dB/Hz	3
Optical Return Loss Tolerance		20			dB	
Receiver Section:						
Center Wavelength	λ_r	1480		1580	nm	
Receiver Sensitivity (OMA)	S_{en}			-23	dBm	4
Stressed Sensitivity (OMA)	$S_{en_{ST}}$			-21	dBm	4
Los Assert	LOS_A	-40		-	dBm	
Los Dessert	LOS_D			-24	dBm	
Los Hysteresis	LOS_H	0.5			dB	
Overload	Sat	-7			dBm	5
Receiver Reflectance	Rrx			-12	dB	

Note:

1. Average power figures are informative only, per IEEE802.3ae.
2. TWDP figure requires the host board to be SFF-8431 compliant. TWDP is calculated using the Matlab code provided in clause 68.6.6.2 of IEEE802.3ae.
3. 12dB reflection.
4. Conditions of stressed receiver tests per IEEE802.3ae. CSRS testing requires the host board to be SFF-8431 compliant.
5. Receiver overload specified in OMA and under the worst comprehensive stressed condition.

● **Контакты разъема SFP slot**

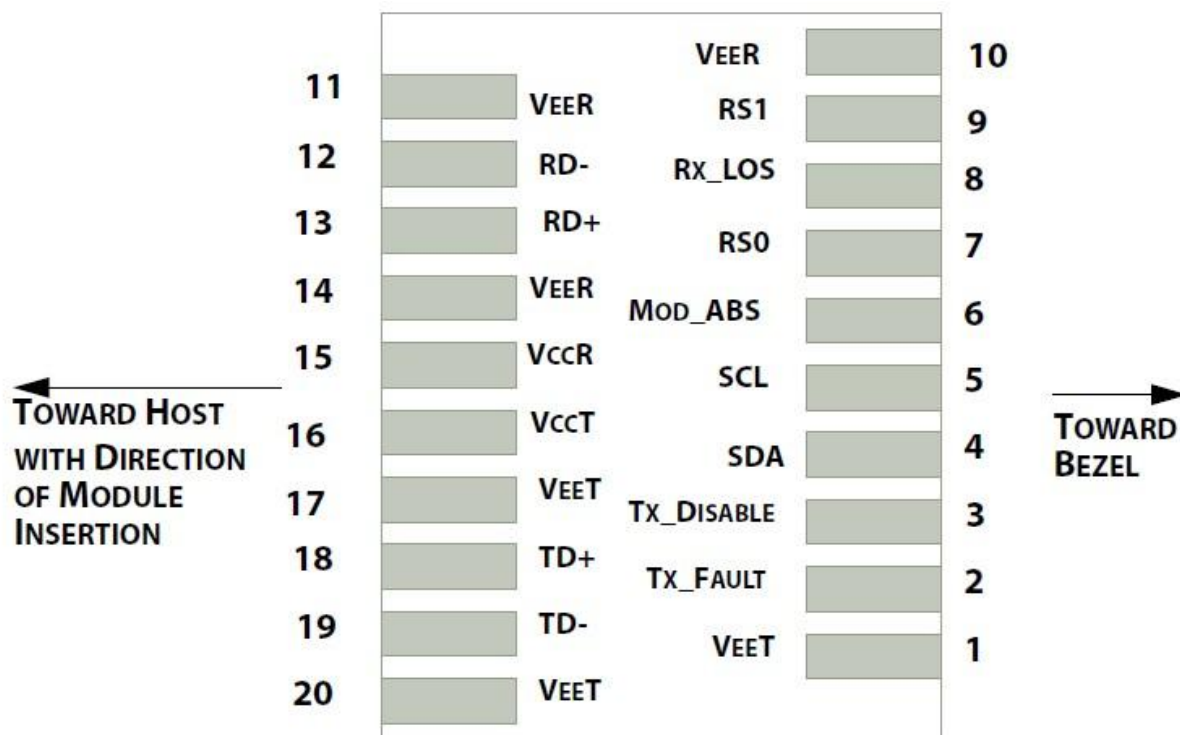

● **Описание контактов**

PIN #	Name	Function	Notes
1	VeeT	Module transmitter ground	1
2	Tx Fault	Module transmitter fault	2
3	Tx Disable	Transmitter Disable; Turns off transmitter laser output	3
4	SDL	2 wire serial interface data input/output (SDA)	
5	SCL	2 wire serial interface clock input (SCL)	
6	MOD-ABS	Module Absent, connect to VeeR or VeeT in the module	2
7	RS0	Rate select0, optionally control SFP+ receiver. When high, input data rate >4.5Gb/ s; when low, input data rate <=4.5Gb/s	
8	LOS	Receiver Loss of Signal Indication	4
9	RS1	Rate select0, optionally control SFP+ transmitter. When	

		high, input data rate >4.5Gb/s; when low, input data rate <=4.5Gb/s	
10	VeeR	Module receiver ground	1
11	VeeR	Module receiver ground	1
12	RD-	Receiver inverted data out put	
13	RD+	Receiver non-inverted data out put	
14	VeeR	Module receiver ground	1
15	VccR	Module receiver 3.3V supply	
16	VccT	Module transmitter 3.3V supply	
17	VeeT	Module transmitter ground	1
18	TD+	Transmitter inverted data out put	
19	TD-	Transmitter non-inverted data out put	
20	VeeT	Module transmitter ground	1

Note:

1. The module ground pins shall be isolated from the module case.
2. This pin is an open collector/drain output pin and shall be pulled up with 4.7K-10Kohms to Host_Vcc on the host board.
3. This pin shall be pulled up with 4.7K-10Kohms to VccT in the module.
This pin is an open collector/drain output pin and shall be pulled up with 4.7K-10Kohms to Host_Vcc on the host board.

● EEPROM и DDMI

The SFP modules implement the 2-wire serial communication protocol as defined in the SFP - 8472. The serial ID information of the SFP modules and Digital Diagnostic Monitor parameters can be accessed through the I²C interface at address A0h and A2h. The memory is mapped in Table 1. Detailed ID information (A0h) is listed in Table 2. And the DDM specification at address A2h. For more details of the memory map and byte definitions, please refer to the SFF-8472, "Digital Diagnostic Monitoring Interface for Optical Transceivers". The DDM parameters have been internally calibrated.

Table 1. Digital Diagnostic Memory Map (Specific Data Field Descriptions)

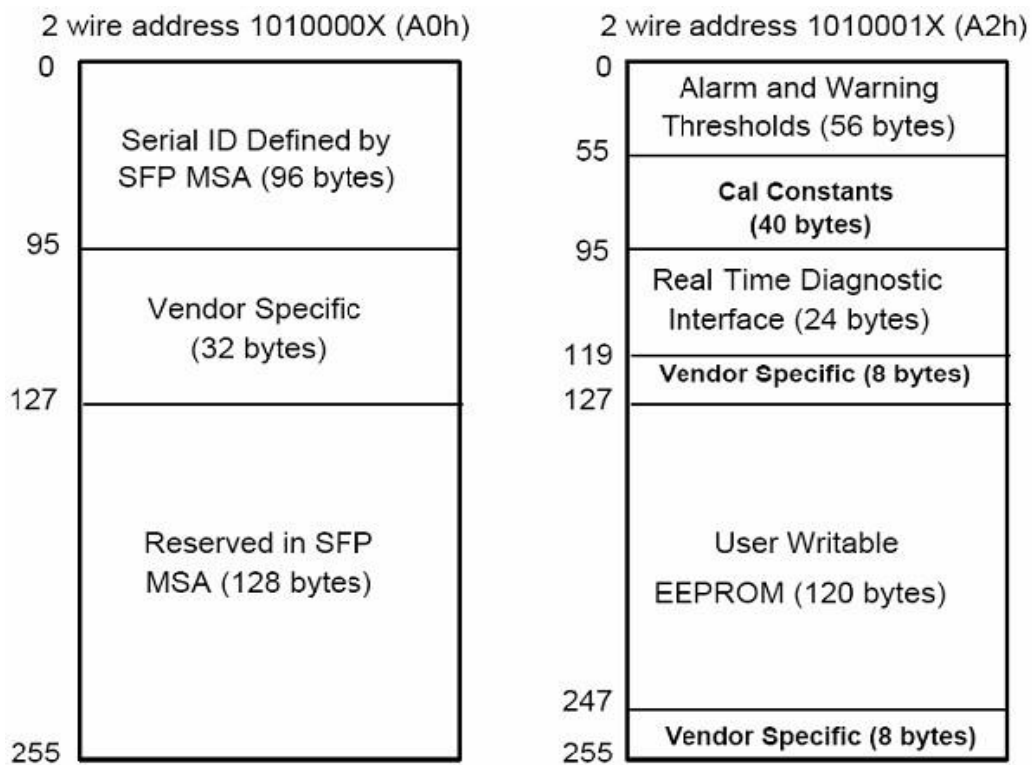

Table 2 - EEPROM Serial ID Memory Contents (A0h)

Data Address	Length (Byte)	Name of Length	Description and Contents
Base ID Fields			
0	1	Identifier	Type of Serial transceiver (03h=SFP)
1	1	Reserved	Extended identifier of type serial transceiver (04h)
2	1	Connector	Code of optical connector type (07=LC)
3-10	8	Transceiver	10G Base-LR
11	1	Encoding	64B/66B
12	1	BR, Nominal	Nominal baud rate

13-14	2	Reserved	(0000h)
15	1	Length(9um)	Link length supported for 9/125um fiber, units of 100m
16	1	Length(50um)	Link length supported for 50/125um fiber, units of 10m
17	1	Length(62.5um)	Link length supported for 62.5/125um fiber, units of 10m
18	1	Length(Copper)	Link length supported for copper, units of meters
19	1	Reserved	
20-35	16	Vendor Name	SFP vendor name: OptTech
36	1	Reserved	
37-39	3	Vendor OUI	SFP transceiver vendor OUI ID
40-55	16	Vendor PN	Part Number (ASCII)
56-59	4	Vendor rev	Revision level for part number
60-62	3	Reserved	
63	1	CCID	Least significant byte of sum of data in address 0-62
Extended ID Fields			
64-65	2	Option	Indicates which optical SFP signals are implemented (001Ah = LOS, TX_FAULT, TX_DISABLE all supported)
66	1	BR, max	Upper bit rate margin, units of %
67	1	BR, min	Lower bit rate margin, units of %
68-83	16	Vendor SN	Serial number (ASCII)
84-91	8	Date code	OptTech Manufacturing date code
92-94	3	Reserved	
95	1	CCEX	Check code for the extended ID Fields (addresses 64 to

			94)
Vendor Specific ID Fields			
96-127	32	Readable	OptTech specific date, read only
128-255	128	Reserved	Reserved for SFF-8079

● Digital Diagnostic Monitor Characteristics

Data Address	Parameter	Accuracy	Unit
96-97	Transceiver Internal Temperature	±3.0	°C
98-99	VCC3 Internal Supply Voltage	±3.0	%
100-101	Laser Bias Current	±10	%
102-103	Tx Output Power	±3.0	dBm
104-105	Rx Input Power	±3.0	dBm

● Рекомендованная схема включения

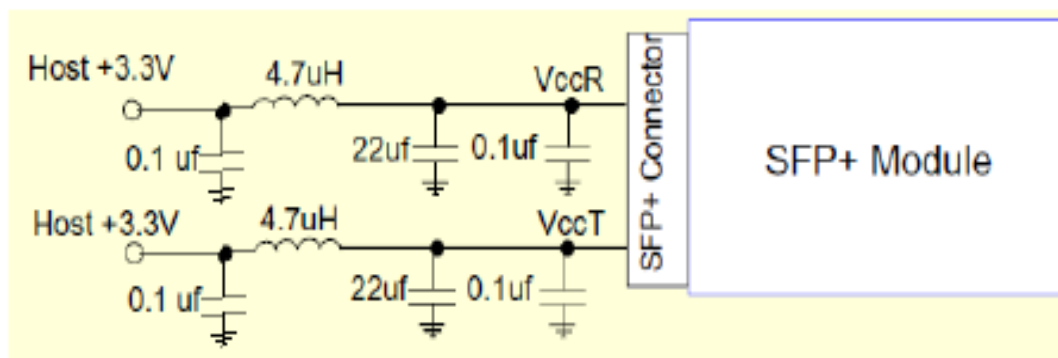

Recommended Host Board Power Supply Circuit

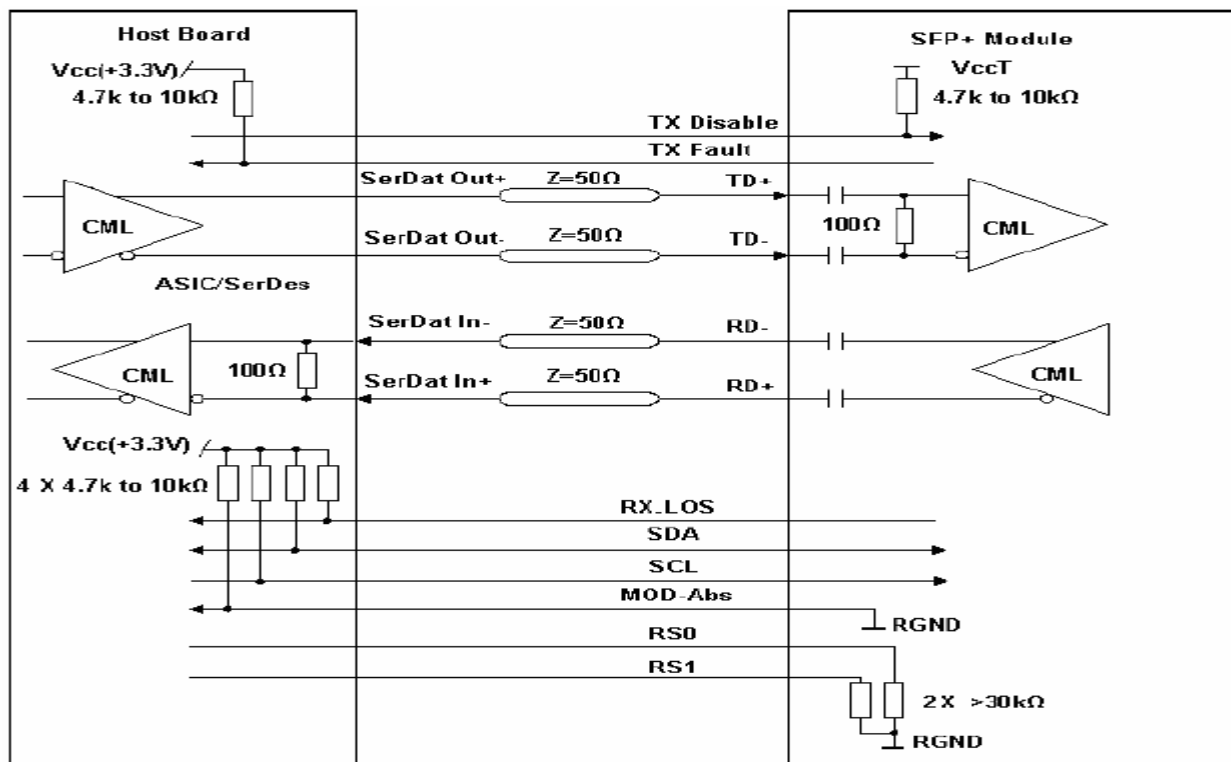

Recommended High-speed Interface Circuit

● Размеры

