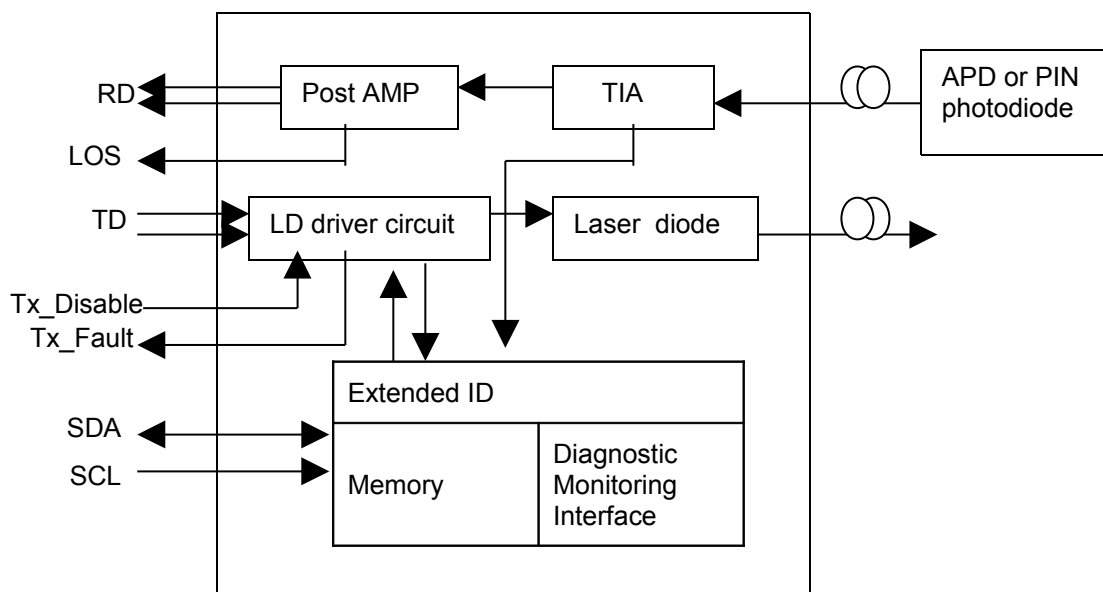

Особенности:

- возможность горячей замены
- DFB 1550нм лазер, 80км бюджет
- двойной LC разъем
- Digital diagnostic monitor interface (DDMI)
- соответствие спецификации SFP MSA и SFF-8472

Области применения:

- Gigabit Ethernet 1000Base-ZX
- STM-1, STM-4

**Функциональная схема:****Спецификация:**

Максимальный режим эксплуатации				
параметр	обозначение	минимум	максимум	единица измерения
Напряжение питания	VCC	0	+3,6	V
Рабочая температура	T _{OP}	0	+75	°C
Рекомендованный режим эксплуатации				
параметр	обозначение	минимум	максимум	единица измерения
Напряжение питания	VCC	+3,1	+3,6	V
Рабочая температура	T _{OP}	-5	+70	°C
Оптические характеристики				

параметр	обозначение	минимум	типовое	максимум	единица измерения
Передатчик					
Выходная мощность	P_0	0		+5	dBm
Отношение Исчезновения	ER	8,2	-	-	dB
Длина волны	λ	1530	1550	1570	nm
Ширина спектра	$\Delta\lambda$	-	-	4	nm
Rise time	Tr			200	ps
Fall time	Tf			200	ps
Выход передатчика	Согласно маски выхода (Eye Mask) определенного стандартом 802.3z				
Приемник					
Чувствительность	Sen	-	-	-24	dBm
максимальная входная мощность	Pmax	-6			dBm
Длина волны	λ	1100	-	1600	nm
Детектирование сигнала	P_A	-	-	-24	dBm
Детектирование сигнала	P_D	-42	-	-	dBm
Return Loss	PL		-	-30	dB
Электрические характеристики					
параметр	обозначение	минимум	типовое	максимум	единица измерения
Передатчик					
Скорость передачи(NRZ)	B	155	-	1250	Mb/s
Напряжение питания	V_{CCT}	+3,1	+3,3	+3,6	V
Ток потребления	I_{CCT}	-	70	130	mA
High уровень	V_{IH}	$V_{CCT} - 1,165$	-	$V_{CCT} - 0,700$	V
Low уровень	V_{IL}	$V_{CCT} - 1,890$	-	$V_{CCT} - 1,475$	V
Напряжение разрешающее передачу	V_{EN}	-	-	0,8	V
Напряжение запрещающее передачу	V_D	2	-	-	V
Приемник					

параметр	обозначение	минимум	типовое	максимум	единица измерения
Скорость передачи(NRZ)	B	155	-	1250	Mb/s
Напряжение питания	V_{CCR}	+3,1	+3,3	+3,6	V
Ток потребления	I_{CCR}	-	80	150	mA
High уровень	V_{OH}	$V_{CCR} - 1,025$	-	$V_{CCR} - 0,880$	V
Low уровень	V_{OL}	$V_{CCR} - 1,810$	-	$V_{CCR} - 1,620$	V
LOS High уровень	V_{LOUT}	-	-	0,8	V
LOS Low уровень	V_{HOUT}	2	-	-	V

Рекомендованная схема включения:

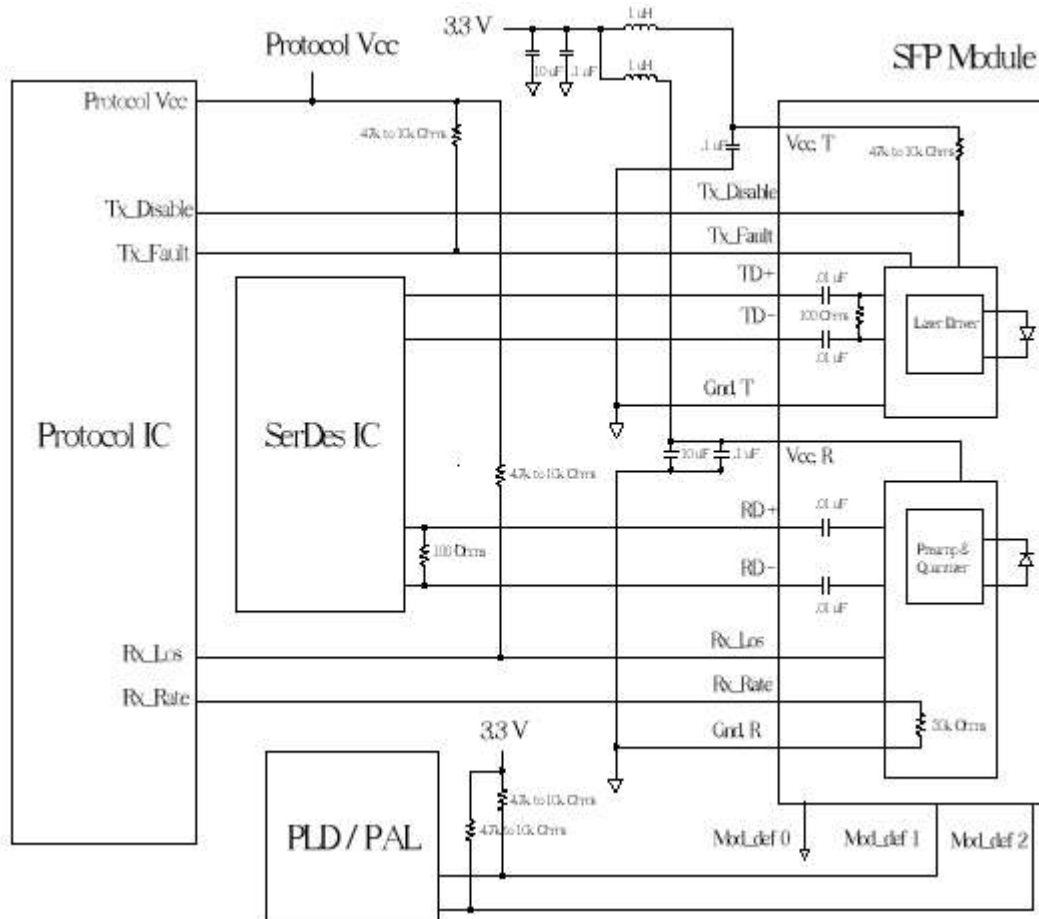

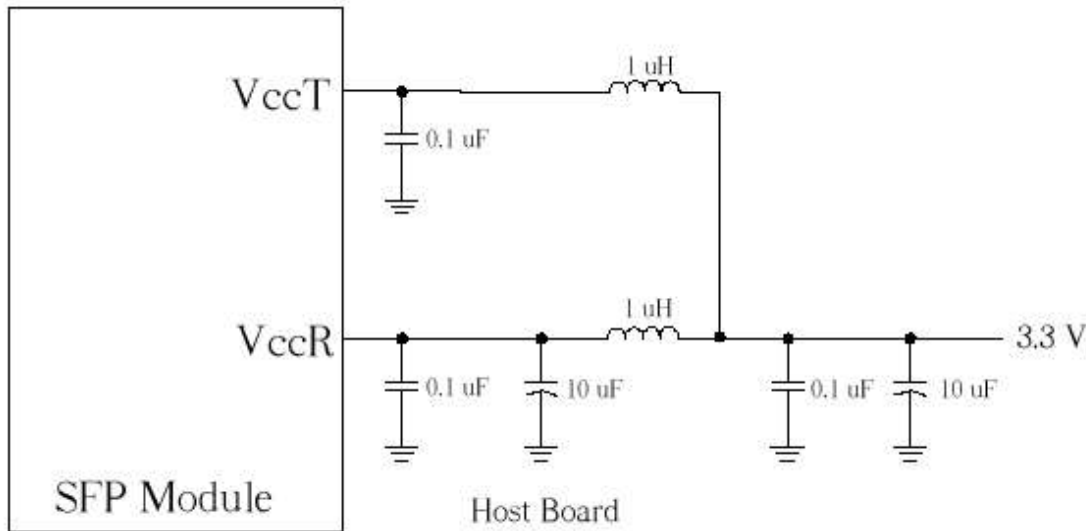
**Описание контактов (PIN):**

Pin Name	PIN	Name/Function
GNDR	9, 10, 11, 14	Receiver Ground
VCCR	15	Receiver Supply Voltage. They are defined as $+3.3V \pm 5\%$ at the SFP connector pin. Recommended host board power supply filtering is shown below. The DC resistance of inductor is less than 1Ω , which result in maintaining the required voltage at the SFP input pin with $+3.3V$ supply voltage.
RD-	12	Receiver Data, Differential Output. They are AC coupled 100Ω differential lines which should be terminated with 100Ω at the user SERDES. The AC coupling is done inside the module and is thus not required on the host board. The voltage swing on these lines will be between $370mV$ and $2000mV$ differential when properly terminated.
RD+	13	Receiver Data, Differential Output. They are AC coupled 100Ω differential lines which should be terminated with 100Ω at the user SERDES. The AC coupling is done inside the module and is thus not required on the host board. The voltage swing on these lines will be between $370mV$ and $2000mV$ differential when properly terminated.
LOS	8	Receiver Loss of Signal, logic high, open collector compatible, $4.7K$ to $10K$ Ohm pull up to VCCR on host
Rate Select	7	NC.
GNDT	1, 17, 20	Transmitter Ground
VCCT	16	Transmitter Supply Voltage. They are defined as $+3.3V \pm 5\%$ at the SFP connector pin. Recommended host board power supply filtering is shown below. The DC resistance of inductor is less than 1Ω , which result in maintaining the required voltage at the SFP input pin with $+3.3V$ supply voltage.
TD+	18	Transmit Data, Differential Input. They are AC coupled 100Ω differential lines which should be terminated with 100Ω inside the module. The AC coupling is done inside the module and is thus not required on the host board.
TD-	19	Transmit Data, Differential Input. They are AC coupled 100Ω differential lines which should be terminated with 100Ω inside the module. The AC coupling is

		done inside the module and is thus not required on the host board.
TX_Disable	3	Transmitter Disable, logic high, open collector compatible, 4.7K to 10K Ohm pull up to VCCT on SFP. The pin is used to shut down the transmitter optical output. High is transmitter Disabled, Low is transmitter on.
TX_Fault	2	Transmitter Fault, logic high, open collector compatible, 4.7K to 10K Ohm pull up to VCCT on host. When high, output indicates a laser fault of some kind. Low indicates normal operation.
MOD_DEF 0	6	SFP module definition and presence, bit 0, 4.7K to 10K Ohm pull up to VCCT on host. The pin is grounded by the module to indicate that the module is present.
MOD_DEF 1	5	SFP module definition and presence, bit 1, 4.7K to 10K Ohm pull up to VCCT on host. The pin is the clock line of two wire serial interface for serial ID
MOD_DER 2	4	SFP module definition and presence, bit 2, 4.7K to 10K Ohm pull up to VCCT on host. The pin is the data line of two wire serial interface for serial ID.

